

ZODIAC CH 640

PERFORMANCE Lycoming O-360, 180 BHP	Take-Off Weight: 1,650 lbs. Typical Load: 518 lbs.		Gross Weight: 2,200 lbs. Useful Load: 1,000 lbs.	
	MAX. LEVEL SPEED	167 MPH	267 km/h	157 MPH
CRUISE SPEED (75%)	154 MPH	246 km/h	150 MPH	240 km/h
STALL SPEED (flaps)	40 MPH	65 km/h	47 MPH	76 km/h
STALL SPEED (no flaps)	50 MPH	81 km/h	58 MPH	93 km/h
RATE OF CLIMB	1,400 fpm	7.0 m/s	950 fpm	4.8 m/s
SERVICE CEILING	16000+ Ft.	4880+ m.	12,800 Ft.	3,900 m.
ENDURANCE (Std.)	3.75 hours	3.75 hours	3.75 hours	3.75 hours
RANGE (Std)	525 miles	845 km.	510 miles	820 km.
TAKE-OFF ROLL	950 Ft.	260 m.	990 Ft.	300 m.
LANDING ROLL	800 Ft.	244 m.	1,150 Ft.	350 m.

Above performance figures with the Lycoming O-360 engine (180 BHP: 420 lbs. with accessories and fixed-pitch Sensenich 76-EM8-0-62 metal propeller). Standard atmosphere, sea level, no wind. All technical data, specification and performance figures subject to change without notice. Cruise: 75% power at 7,000 ft. ASL. Endurance and range figures without fuel reserve.

SPECIFICATIONS	ZODIAC CH 640	
LENGTH	23 Feet	7.0 m.
HEIGHT	7 ft. 4 in.	2.25 m.
WING SPAN	31 ft. 6 in.	9.6 m.
WING AREA	150 sq.ft.	14 m.sq.
WING CHORD	4 ft. 9.5 in.	1.46 m.
HORIZONTAL TAIL SPAN	9 ft. 10 in.	3.0 m.
HORIZONTAL TAIL AREA	30 sq.ft.	2.8 m.sq.
EMPTY WEIGHT*	1,147 lbs.	545 kg.
DESIGN GROSS WEIGHT	2,200 lbs.	1,000 kg
USEFUL LOAD	1,053 lbs.	454 kg.
FUEL CAPACITY (standard)	38 US Gallons (2 x 19)	144 l. (2 x 72)
– Fuel Weight (standard)	230 lbs.	104 kg.
FUEL CAPACITY (Extended Range Option)	46 US Gallons (2 x 23)	174 l. (2 x 87)
– Fuel Weight (Extended Range Option)	275 lbs.	125 kg.
DESIGN PAYLOAD (Occupants + Baggage)	796 lbs. (4 x 199 lbs.)	360 kg. (4 x 90 kg.)
WING LOADING	14.6 lbs./sq.ft.	71.4 kg./m.sq.
POWER LOADING	12.2 lbs./BHP	5.55 kg./BHP
CABIN WIDTH	46 in.	117 cm.
CABIN LENGTH (rear seat to rudder pedals)	74 in.	188 cm.
DESIGN LOAD FACTOR (ultimate)	+5.7 / -2.9	+5.7 / -2.9

* Basic empty weight: Prototype aircraft equipped with the Lycoming O-360 (with 60 amp alternator, starter, Gill 35 battery, seats with upholstery, 600 x 6 main wheels with dual caliper brakes, 500 x 5 nosewheel, metal fixed pitch propeller, complete night flight package (lighting system), and instrument gyros. Suitable power: 150 - 240 hp; up to 440 lbs. installed. Other installed equipment will effect empty weight and performance of the aircraft. Technical data, specification and performance figures subject to change without notice.

Represented & manufactured by

Zenair Ltd.

Huronia Airport, Midland, ON Canada L4R 4K8

705-526-2871 FAX: 705-526-8022

www.zenair.com

ZODIAC CH 640

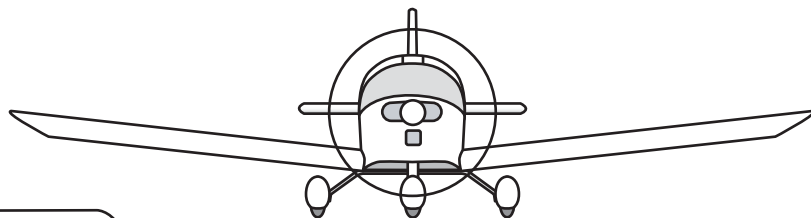
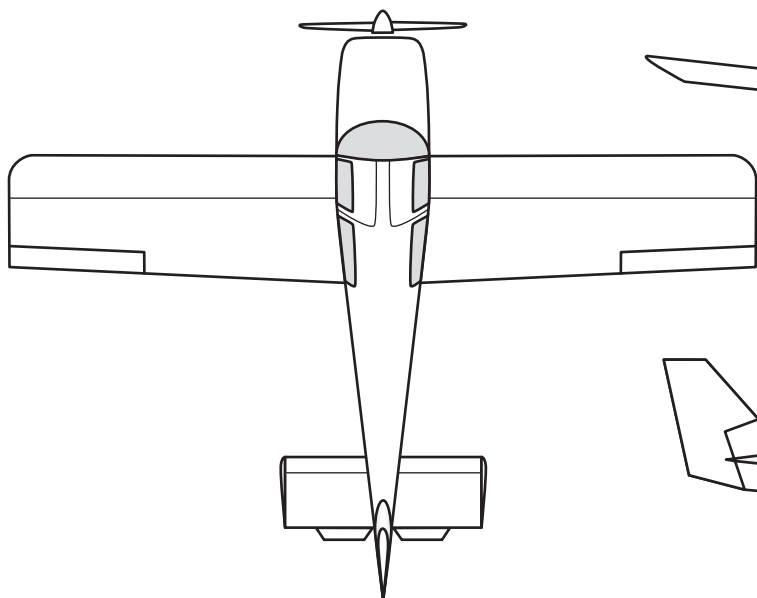

A **Kit Airplane**
For the **Family**

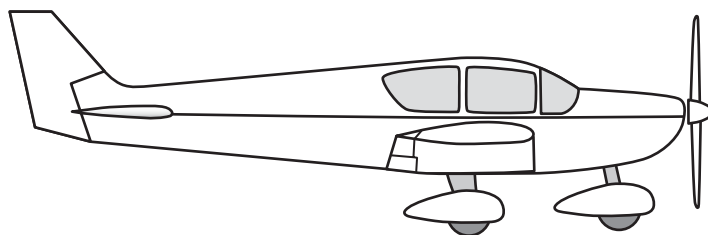

New Four-Seat All-Metal Kit Aircraft Design

- ★ Roomy 2 + 2 Seating Arrangement
- ★ Huge 46-inch Wide Cabin
- ★ Dual Gull-Wing Doors
- ★ New design based on the type-certificated CH 2000
- ★ Durable yet simple all-metal construction
- ★ Great Family Airplane
- ★ Good Cross-Country Capability
- ★ Conventional Controls & Handling
- ★ New QUICK-BUILD kits
- ★ Simple Construction for First-Time Builders

ZODIAC CH 640 – Complete Airframe Kit

The standard ZODIAC CH 640 kit comes with all kit parts to build the airframe: The complete kit includes the factory riveted wing spars, pre-formed sheet-metal parts (ribs, skins, etc.), factory-welded parts, landing gear system and wheels, standard fuel system, controls, and all hardware required for assembly. Items not included in the airframe kit: firewall-forward package, powerplant and propeller, instruments packages, electrical package, paint, and upholstery. Manuals are included. Average kit assembly time: 1,250 hours.

Complete Airframe Kit

\$ 24,800.00

ZODIAC CH 640 – QUICK-BUILD Kit

The Quick-Build Kit reduces the building time to approximately 750 assembly hours. The Quick-Build kit includes the same items as the standard airframe kit. The fuselage, wings, ailerons and flaps and stabilator are assembled on factory jigs. Assembling the aircraft rudder and wings tip extensions must be completed by the builder. The builder must complete the final assembly of all sections to meet the requirements of the FAA "51%" rule.

QUICK-BUILD Kit:

\$ 35,190.00

A firewall forward package for the Lycoming O-360 is available, as well as custom options for the kit. Prices in US Funds, F.O.B. Factory. Prices, equipment and availability subject to change without notice. Schematic not to scale.

**“Handling is solid and friendly, as a family cruiser should be...
the CH640 handles predictably and lands almost without conscious thought.
It appears that Zenair has produced another winner,
a worthy addition to the two-seat line that preceded it.”**

– “A Kit Airplane for the Family,” CustomPlanes magazine

7/2006: 640-3v.ai

www.zenair.com

Zenair Ltd.

Huronon Airport, Midland, ON Canada L4R 4K8
705-526-2871 FAX: 705-526-8022